

TST - A-1MA

VHM - Kugelfräser mit Freilänge
Solid carbide ball nose end mill with free length



Ø-Bereich / Ø-range: 0,60 - 2,50 mm

Formgenauigkeit / accuracy of shape:
 $R \leq 1,25$ mm: +/- 0,010 mm

Durchmessertoleranz / diameter tolerance:
 $\varnothing \leq 2,50$ mm: 0/-0,010 mm

Anwendung / application:

- PMMA Kunststoffe / PMMA plastics
- PEEK Kunststoffe / PEEK plastics
- Wachs / WAX
- A.B.S Kunststoffe / A.B.S plastics
- NE-Metalle / non-ferrous metals
- nichtmetallischen Werkstoffen / non-metallic materials

Merkmale / characteristics:

- unbeschichtet / uncoated
- 30° Helix / helix
- 1 Schneide / flute

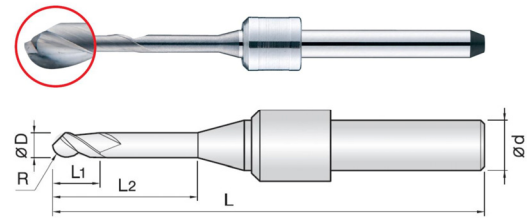

Bestell-Nr. Order No.	D	R	L1	L2	L	d	PG 40	
							Stück / piece	
690.022001	0,60	0,30	2	7	47	3	€ 63,04	
690.022002	1,00	0,50	6	17	47	3	€ 55,89	
690.022003	2,50	1,25	9	17	47	3	€ 58,21	

TST - A-2MA / A-3MA

VHM - Kugelfräser mit Freilänge
Solid carbide ball nose end mill with free length

Ø-Bereich / Ø-range: 0,60 - 2,50 mm

Formgenauigkeit / accuracy of shape:
 $R \leq 1,25$ mm: +/- 0,010 mm

Durchmessertoleranz / diameter tolerance:
 $\varnothing \leq 2,50$ mm: 0/-0,010 mm

Anwendung / application:

- Zirkonoxid / zirconia
- Ultimate Kunststoffe / ultimate plastics
- NE-Metalle / non-ferrous metals
- nichtmetallischen Werkstoffen / non-metallic materials

Merkmale / characteristics:

- NANO Diamant-Beschichtung / NANO diamond coating
- 30° Helix / helix
- 2/3 Schneiden / flutes

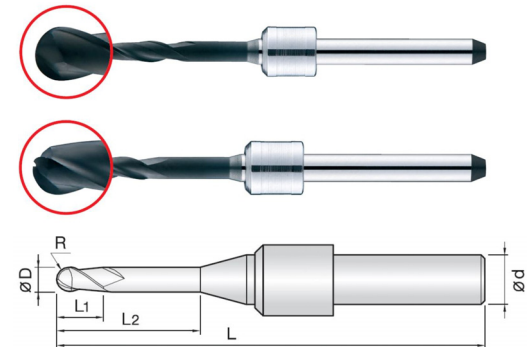

Bestell-Nr. Order No.	D	R	L1	L2	L	d	Schneiden flutes	PG 35	
								Stück / piece	
690.023001	0,60	0,30	2	7	47	3	2	€ 75,00	
690.023002	1,00	0,50	6	17	47	3	2	€ 64,29	
690.023003	1,00	0,50	6	17	47	3	3	€ 67,14	
690.023004	2,50	1,25	9	17	47	3	2	€ 66,57	
690.023005	2,50	1,25	9	17	47	3	3	€ 69,57	