

TST - R-10L

VHM - Kugelfräser mit Freilänge
Solid carbide ball nose end mill with free length



Ø-Bereich / Ø-range: 0,60 - 3,00 mm

Formgenauigkeit / accuracy of shape:

R ≤ 1,50 mm: +/- 0,010 mm

Durchmessertoleranz / diameter tolerance:

Ø ≤ 3,00 mm: 0/-0,010 mm

Anwendung / application:

- PMMA Kunststoffe / PMMA plastics
- PEEK Kunststoffe / PEEK plastics
- Wachs / WAX
- A.B.S Kunststoffe / A.B.S plastics
- NE-Metalle / non-ferrous metals
- nichtmetallischen Werkstoffen / non-metallic materials

Merkmale / characteristics:

- unbeschichtet / uncoated
- 30° Helix / helix
- 1 Schneide / flute

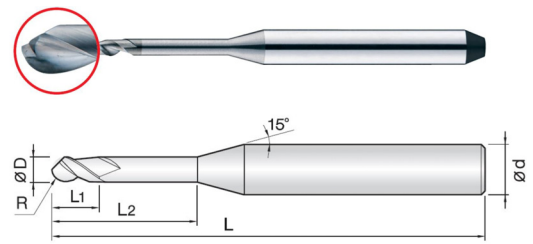

Bestell-Nr. Order No.	D	R	L1	L2	L	d	PG 40	
							Stück / piece	
690.004001	0,60	0,30	2	6	50	4	€ 51,43	
690.004002	0,60	0,30	2	14	50	4	€ 51,96	
690.004003	1,00	0,50	6	16	50	4	€ 45,18	
690.004004	1,00	0,50	6	20	50	4	€ 49,64	
690.004005	2,00	1,00	8	20	50	4	€ 47,14	
690.004006	3,00	1,50	10	20	50	4	€ 49,64	

komppatible Maschinen / compatible machines: Roland DWX 50, DWX 30, DWX 51D

TST - R-20L / R-30L

VHM - Kugelfräser mit Freilänge
Solid carbide ball nose end mill with free length

Ø-Bereich / Ø-range: 0,60 - 3,00 mm

Formgenauigkeit / accuracy of shape:

R ≤ 1,50 mm: +/- 0,010 mm

Durchmessertoleranz / diameter tolerance:

Ø ≤ 3,00 mm: 0/-0,010 mm

Anwendung / application:

- Zirkonoxid / zirconia
- Ultimate Kunststoffe / ultimate plastics
- NE-Metalle / non-ferrous metals
- nichtmetallischen Werkstoffen / non-metallic materials

Merkmale / characteristics:

- NANO Diamant-Beschichtung / NANO diamond coating
- 30° Helix / helix
- 2/3 Schneiden / flutes

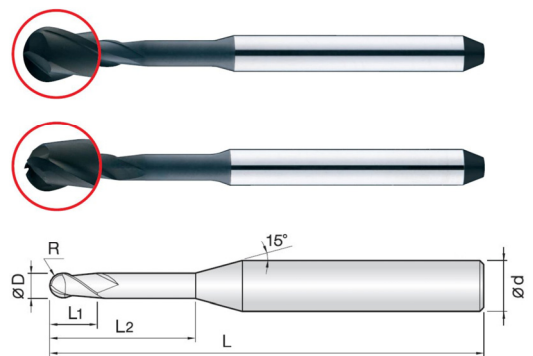

Bestell-Nr. Order No.	D	R	L1	L2	L	d	Schneiden flutes	PG 35	
								Stück / piece	
690.005001	0,60	0,30	2	6	50	4	2	€ 74,14	
690.005002	0,60	0,30	2	14	50	4	2	€ 76,00	
690.005003	1,00	0,50	6	16	50	4	2	€ 64,00	
690.005004	1,00	0,50	6	16	50	4	3	€ 68,43	
690.005005	1,00	0,50	6	20	50	4	2	€ 66,14	
690.005006	1,00	0,50	6	20	50	4	3	€ 70,71	
690.005007	2,00	1,00	8	20	50	4	2	€ 66,14	
690.005008	2,00	1,00	8	20	50	4	3	€ 70,71	
690.005009	3,00	1,50	10	20	50	4	2	€ 66,14	
690.005010	3,00	1,50	10	20	50	4	3	€ 70,71	

komppatible Maschinen / compatible machines: Roland DWX 50, DWX 30, DWX 51D