

TST - V-1HF

VHM - Kugelfräser mit Freilänge
Solid carbide ball nose end mill with free length



Ø-Bereich / Ø-range: 0,60 - 2,00 mm

Formgenauigkeit / accuracy of shape:

R ≤ 1,00 mm: +/- 0,010 mm

Durchmessertoleranz / diameter tolerance:

Ø ≤ 2,00 mm: 0/-0,010 mm

Anwendung / application:

- PMMA Kunststoffe / PMMA plastics
- PEEK Kunststoffe / PEEK plastics
- Wachs / WAX
- A.B.S Kunststoffe / A.B.S plastics
- NE-Metalle / non-ferrous metals
- nichtmetallischen Werkstoffen / non-metallic materials

Merkmale / characteristics:

- unbeschichtet / uncoated
- 30° Helix / helix
- 1 Schneide / flute

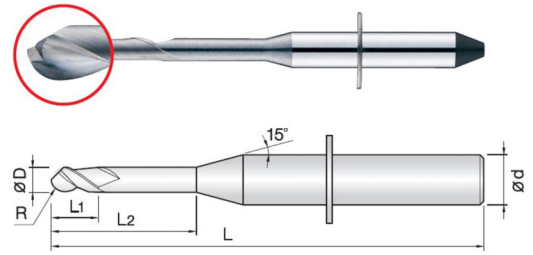

Bestell-Nr. Order No.	D	R	L1	L2	L	d	PG 40	
							Stück / piece	
690.006001	0,60	0,30	2	7	35	3	€ 60,36	
690.006002	0,60	0,30	2	11	35	3	€ 62,14	
690.006003	1,00	0,50	5	16	35	3	€ 53,21	
690.006004	2,00	1,00	8	17	35	3	€ 55,54	

kompatible Maschinen / compatible machines: 4Axes / Wieland / Brux Zir / EzMill / Jensen

TST - V-2HF / V-3HF

VHM - Kugelfräser mit Freilänge
Solid carbide ball nose end mill with free length

Ø-Bereich / Ø-range: 0,60 - 2,00 mm

Formgenauigkeit / accuracy of shape:

R ≤ 1,00 mm: +/- 0,010 mm

Durchmessertoleranz / diameter tolerance:

Ø ≤ 2,00 mm: 0/-0,010 mm

Anwendung / application:

- Zirkonoxid / zirconia
- Ultimate Kunststoffe / ultimate plastics
- NE-Metalle / non-ferrous metals
- nichtmetallischen Werkstoffen / non-metallic materials

Merkmale / characteristics:

- unbeschichtet / uncoated
- 30° Helix / helix
- 2/3 Schneiden / flutes

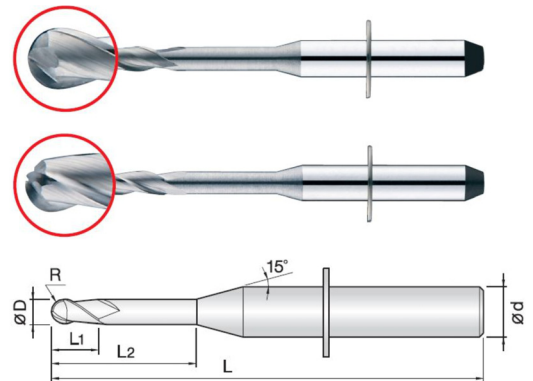

Bestell-Nr. Order No.	D	R	L1	L2	L	d	Schneiden flutes	PG 40	
								Stück / piece	
690.007001	0,60	0,30	2	7	35	3	2	€ 55,00	
690.007002	0,60	0,30	2	11	35	3	2	€ 56,43	
690.007003	1,00	0,50	5	16	35	3	2	€ 48,39	
690.007004	1,00	0,50	5	16	35	3	3	€ 51,79	
690.007005	2,00	1,00	8	17	35	3	2	€ 50,54	
690.007006	2,00	1,00	8	17	35	3	3	€ 53,93	

kompatible Maschinen / compatible machines: 4Axes / Wieland / Brux Zir / EzMill / Jensen