

TST - V-2HFD / V-3HFD

VHM - Kugelfräser mit Freilänge
Solid carbide ball nose end mill with free length



Ø-Bereich / Ø-range: 0,60 - 2,00 mm

Formgenauigkeit / accuracy of shape:

$R \leq 1,00$ mm: +/- 0,010 mm

Durchmessertoleranz / diameter tolerance:

$\varnothing \leq 2,00$ mm: 0/-0,010 mm

Anwendung / application:

- Zirkonoxid / zirconia
- Ultimate Kunststoffe / ultimate plastics
- NE-Metalle / non-ferrous metals
- nichtmetallischen Werkstoffen / non-metallic materials

Merkmale / characteristics:

- NANO Diamant-Beschichtung / NANO diamond coating
- 30° Helix / helix
- 2/3 Schneiden / flutes

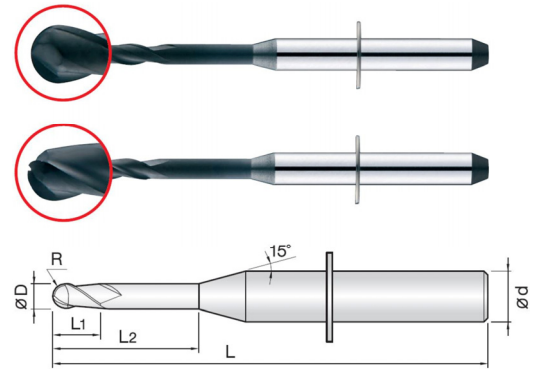

Bestell-Nr. Order No.	D	R	L1	L2	L	d	Schneiden flutes	PG 35
								Stück / piece
690.008001	0,60	0,30	2	7	40	3	2	€ 71,57
690.008002	0,60	0,30	2	11	40	3	2	€ 73,29
690.008003	1,00	0,50	5	17	40	3	2	€ 62,86
690.008004	1,00	0,50	5	17	40	3	3	€ 67,14
690.008005	2,00	1,00	8	17	40	3	2	€ 65,43
690.008006	2,00	1,00	8	17	40	3	3	€ 70,00

kompatible Maschinen / compatible machines: 5Axes / Wieland / Brux Zir / EzMill / Jensen

TST - W-1IE

VHM - Kugelfräser mit Freilänge
Solid carbide ball nose end mill with free length

Ø-Bereich / Ø-range: 0,60 - 2,50 mm

Formgenauigkeit / accuracy of shape:

$R \leq 1,25$ mm: +/- 0,010 mm

Durchmessertoleranz / diameter tolerance:

$\varnothing \leq 2,50$ mm: 0/-0,010 mm

Anwendung / application:

- PMMA Kunststoffe / PMMA plastics
- PEEK Kunststoffe / PEEK plastics
- Wachs / WAX
- A.B.S Kunststoffe / A.B.S plastics
- NE-Metalle / non-ferrous metals
- nichtmetallischen Werkstoffen / non-metallic materials

Merkmale / characteristics:

- unbeschichtet / uncoated
- 30° Helix / helix
- 1 Schneide / flute

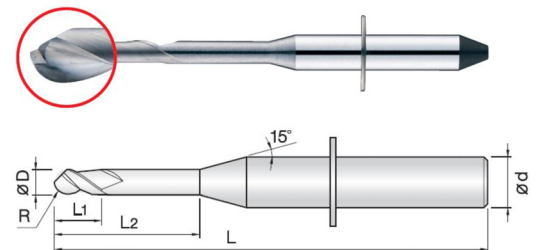

Bestell-Nr. Order No.	D	R	L1	L2	L	d	PG 40
							Stück / piece
690.009001	0,60	0,30	2	7	35	3	€ 60,36
690.009002	0,60	0,30	2	7	40	3	€ 60,36
690.009003	0,70	0,35	2	7	35	3	€ 60,36
690.009004	0,70	0,35	2	7	40	3	€ 60,36
690.009005	1,00	0,50	5	16	35	3	€ 53,21
690.009006	1,00	0,50	5	17	40	3	€ 53,21
690.009007	2,00	1,00	8	17	35	3	€ 55,54
690.009008	2,00	1,00	8	17	40	3	€ 55,54
690.009009	2,50	1,25	10	20	35	3	€ 58,39
690.009010	2,50	1,25	10	20	40	3	€ 58,39

kompatible Maschinen / compatible machines: Wieland Mini / Wieland Select