

TST - Z-2IRD / Z-3IRD

VHM - Kugelfräser mit Freilänge
Solid carbide ball nose end mill with free length



Ø-Bereich / Ø-range: 0,50 - 2,00 mm

Formgenauigkeit / accuracy of shape:
R ≤ 1,00 mm: +/- 0,010 mm

Durchmessertoleranz / diameter tolerance:
Ø ≤ 2,00 mm: 0/-0,010 mm

Anwendung / application:

- Zirkonoxid / zirconia
- Ultimate Kunststoffe / ultimate plastics
- NE-Metalle / non-ferrous metals
- nichtmetallischen Werkstoffen / non-metallic materials

Merkmale / characteristics:

- NANO Diamant-Beschichtung / NANO diamond coating
- 30° Helix / helix
- 2/3 Schneiden / flutes

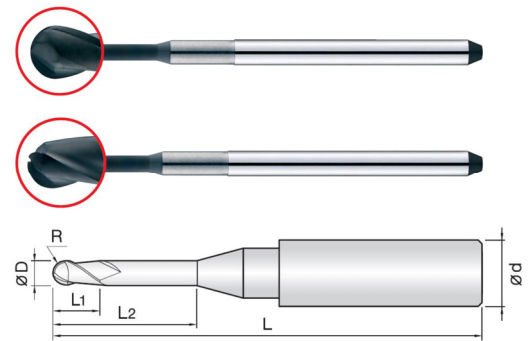

Bestell-Nr. Order No.	D	R	L1	L2	L	d	Schneiden flutes	PG 35
								Stück / piece
690.020001	0,50	0,25	3	5	57	3	2	€ 76,86
690.020002	0,50	0,25	3	5	50	6	2	€ 85,43
690.020003	1,00	0,50	8	16	57	3	2	€ 70,43
690.020004	1,00	0,50	8	16	57	3	3	€ 75,29
690.020005	1,00	0,50	6	12	50	6	2	€ 74,00
690.020006	1,00	0,50	6	12	50	6	3	€ 79,14
690.020007	2,00	1,00	10	18	57	3	2	€ 73,86
690.020008	2,00	1,00	10	18	57	3	3	€ 79,00
690.020009	2,00	1,00	10	18	50	6	2	€ 76,29
690.020010	2,00	1,00	10	18	50	6	3	€ 81,57

kompatible Maschinen / compatible machines: ZIRKONZAHN M1, M5

TST - Z-2IRT

VHM - Kugelfräser mit Freilänge
Solid carbide ball nose end mill with free length

Ø-Bereich / Ø-range: 2,00 - 3,00 mm

Formgenauigkeit / accuracy of shape:
R ≤ 1,50 mm: +/- 0,010 mm

Durchmessertoleranz / diameter tolerance:
Ø ≤ 3,00 mm: 0/-0,010 mm

Anwendung / application:

- Titan / titanium
- Kobalt-Chrom / cobalt-chrome
- Abutment Kunststoffe / abutment plastics

Merkmale / characteristics:

- TiSiN-Beschichtung / TiSiN coating
- 30° Helix / helix
- 2 Schneiden / flutes

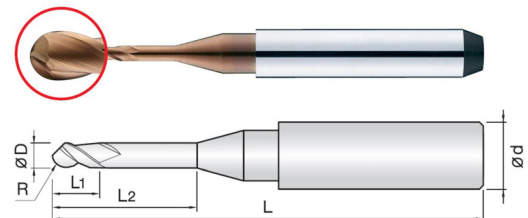

Bestell-Nr. Order No.	D	R	L1	L2	L	d	PG 40
							Stück / piece
690.021001	2,00	1,00	3	18	50	6	€ 58,75
690.021002	3,00	1,50	4	18	50	6	€ 58,75

kompatible Maschinen / compatible machines: ZIRKONZAHN M1