

TST - D-3RE

VHM - Schafffräser mit Freilänge
Solid carbide end mill with free length



Ø-Bereich / Ø-range: 1,00 - 12,00 mm

Durchmessertoleranz / diameter tolerance:

Ø ≤ 5,00 mm: 0/-0,010 mm

Ø ≤ 12,00 mm: -0,010/-0,025 mm

Anwendung / application:

- NE-Metalle / non-ferrous metals
- Aluminium / aluminum
- Aluminiumlegierungen / aluminum alloys
- Kupfer / copper
- Kupferlegierungen / copper alloys

Merkmale / characteristics:

- DLC-Beschichtung / DLC coating
- 45° Helix / helix
- 3 Schneiden / flutes

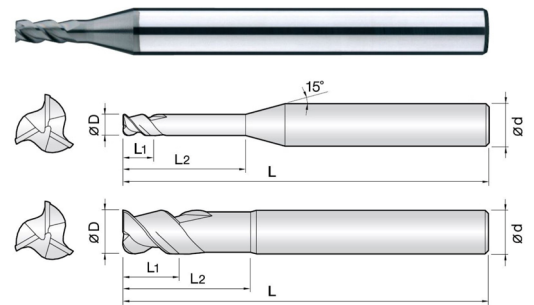

Bestell-Nr. Order No.	D	L1	L2	L	d	PG 40
						Stück / piece
600.168001	1,00	2	3	50	4	€ 45,50
600.168002	1,50	3	4,5	50	4	€ 45,50
600.168003	2,00	4	6	50	4	€ 45,50
600.168004	2,50	5	7,5	50	4	€ 47,50
600.168005	3,00	6	9	60	6	€ 47,50
600.168006	4,00	9	12	60	6	€ 53,50
600.168007	5,00	10	15	70	6	€ 53,50
600.168008	6,00	12	18	70	6	€ 53,50
600.168009	8,00	16	24	80	8	€ 78,00
600.168010	10,00	20	30	90	10	€ 111,68
600.168011	12,00	24	36	100	12	€ 138,33